

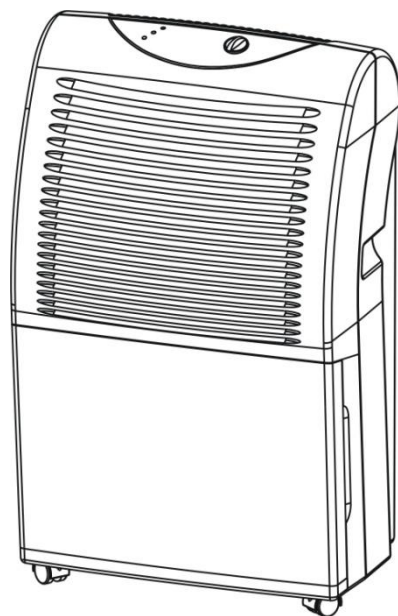

Meaco 30L and Meaco 40L dehumidifier instruction manual



Please read this instruction manual before using the dehumidifier and keep safe
for future reference

SAFETY INSTRUCTIONS

PLEASE READ ALL INSTRUCTIONS CAREFULLY BEFORE OPERATING.

In case of a failure whilst under warranty we will collect the dehumidifier from you for repair/replacement, therefore please save the packaging and keep it safe away from children. When you do dispose of the packaging please recycle.

WARNING - This appliance is intended for use in a domestic environment only. Any other use is not recommended by the manufacturer and may cause fire, electrical shocks or other injury to person or property. When using electrical appliances, basic safety precautions should always be followed:

1. Do not operate the unit with a damaged cord or plug, after it malfunctions or has been dropped or damaged in any way. Return to an authorized service facility for examination and repair.
2. This unit should always be kept in an upright position to avoid any damage. Locate the unit on a flat stable surface.
3. Check the household voltage to ensure it matches the units rated specification before operating.
4. Operate this unit in an ambient temperature between 5°C and 35°C.
5. Ensure that the air inlets and outlets are not blocked or covered.
6. Do not place the unit too close to curtains or other objects - minimum 30cm.
7. When using the "MAX" setting" to speed up the drying of wet clothes in the room, keep the clothing at a safe distance from the dehumidifier to prevent water from dropping onto the unit.
8. Never place anything on top of the unit and do not cover with any kind of material while in use.
9. This product is intended for domestic and light commercial use ONLY and not for commercial, industrial or outdoor use.
10. To protect against electrical shocks, do not immerse unit, plug or cord in water, or spray with liquids.
11. Never unplug the power cord without press the turning the control knob to off first, as this could damage the unit. Never unplug the dehumidifier before the fan has stopped blowing.
12. Always unplug the unit when not in use or moving location. To disconnect from the power supply, grip the plug and pull from the power socket. Never pull by the cord.
13. Always empty the water tank before storing the unit away.
14. Close supervision is necessary when any appliance is used by or near children and pets.
15. Do not run power cord under carpeting, or cover with rugs or runners. Arrange the cord away from areas where it may be tripped over.
16. Never operate or store the unit in direct sunlight.
17. To repair the unit, take it to a qualified service engineer. Repairs carried out by unqualified people may cause damage to the unit or injury to persons or property and void the warranty.
18. Where possible, avoid the use of an extension cable as they may overheat and cause a risk of fire. Only use an extension cord after ensuring it is in perfect condition.
19. Do not use the unit without the air filter as this will allow dirt to gather inside the dehumidifier and could invalidate the warranty.
20. Check the filter regularly in order to keep it clean as per page 13. A dirty filter will restrict the air flow into the machine which will increase the resistance on the fan and could result in damage and might invalidate the warranty.

PRODUCT DESCRIPTION

1. Control panel
2. Front panel (Air inlet)
3. Water tank
4. Side panel
6. Air outlet
7. Continuous drainage outlet
8. Power cord
9. Castor

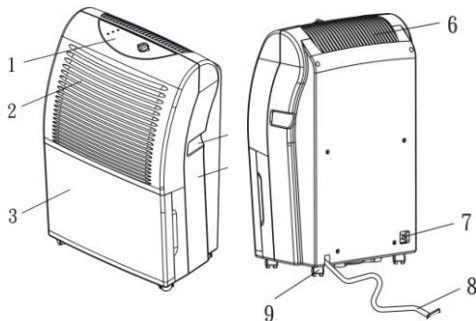

BS PLUG WIRING

Wiring Instructions: Should it be necessary to change the plug please note the wires in the mains lead are coloured in accordance with the following code:

BLUE - NEUTRAL

BROWN - LIVE

GREEN AND YELLOW – EARTH

As the colours of the wires in the mains lead of this appliance may not correspond with the coloured markings identifying the terminals in your plug, proceed as follows:

1. The **BLUE** wire is the **NEUTRAL** and must be connected to the terminal which is marked with the letter **N** or coloured **BLACK**.
2. The **BROWN** wire is the **LIVE** and must be connected to the terminal which is marked with the letter **L** or coloured **RED**.
3. The **GREEN/YELLOW** is the **EARTH** and must be connected to the terminal which is marked with the letter **E** or  or coloured **GREEN OR GREEN/YELLOW**.
4. Always ensure that the cord grip is positioned and fastened correctly.

If a **13A (BS 1363)** fused plug is used it must be fitted with a **13A** fuse. If in doubt consult a qualified electrician.

Wiring for a 13 Amp Plug (BS1363)

Please note. The Earth Terminal is marked with the letter **E** or  Earth Symbol.

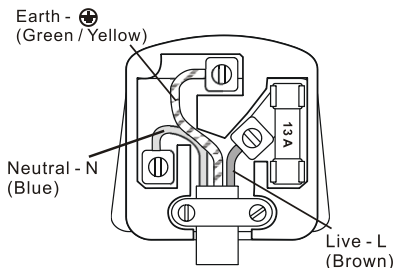

THE CONTROL PANEL

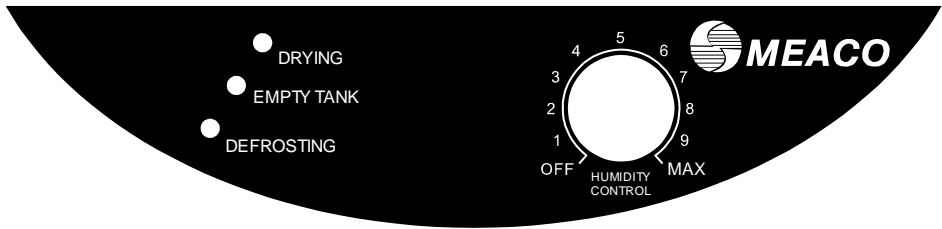

Starting the unit:

1. Turn the humidity control switch to the "OFF" position.
2. Plug in the dehumidifier.
3. Turn the humidity control switch in a clockwise direction.
4. If you are drying a space out after a flood or are looking to achieve maximum dehumidification then set the switch to Maximum.
5. For any other application we recommend turning the switch around to Maximum (MAX) when you first use the dehumidifier and then when the relative humidity has reduced to an acceptable level turn the knob back anti-clockwise until you hear a faint click and leave the dehumidifier at this point. The dehumidifier will turn itself on and off to maintain the relative humidity at a constant level within the space.

When the dehumidifier is dehumidifying the Drying light will be on. If the Drying light is off then the relative humidity is below the relative humidity that it has been set for.

Turning off the unit

1. Turn the humidity control switch anti-clockwise to the "OFF" position.
2. If the dehumidifier is not in use for a long time, please disconnect the power cord plug from the outlet.

Defrosting

When the dehumidifier is being used below 15°C there is a possibility that ice will start to form on the cooling coils, this is quite normal for a compressor type dehumidifier. When this happens the dehumidifier will start to defrost itself and the defrost light will come on. The colder the room temperature and the lower the relative humidity, the more often that this will happen.

DEHUMIDIFIER SETUP AND USE

- Place the dehumidifier in an upright position on a stable, flat surface.
- Please ensure the unit is a safe distance away from a wall or furniture.
- Please keep clothes at a safe distance of 30cm away from the air inlet or outlet to prevent water from dripping into the unit.
- Ensure the tank is correctly fitted, if the tank is full or is not in place, the “Empty Tank” light comes on, an alarm will sound and the dehumidifier will turn off.
- Turn the Humidity Control knob to the desired setting.

To operate safely

- Do not insert small objects into the unit or this will damage it and cause a hazard.
- Do not remove the tank when the dehumidifier is running or water may leak.
- Minimum operating condition 5°C at 50%rh relative humidity.

EMPTYING THE WATER

Emptying the tank

1. When the tank is full the dehumidifier will stop working.
2. Remove the tank as shown below and pour the water away.
3. Take the opportunity to check the filter, clean if required.
4. Reinsert the tank.

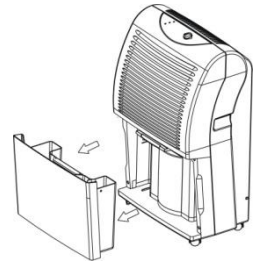

Continuous drainage

1. Take out the drainage plug from the continuous water out hole (fig.1).
2. Take out the water tank (see fig. 2).
3. Put in the drainage plug to the water hole (see fig. 3).
4. Put in the water tank (see fig. 4).
5. Attach a hose to the outlet (see fig.5).

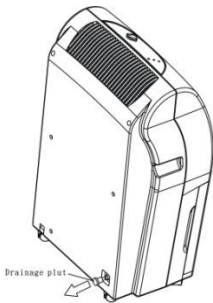

fig.1

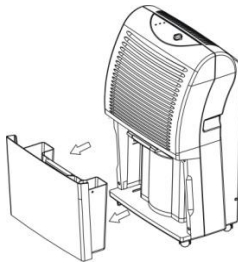

fig.2

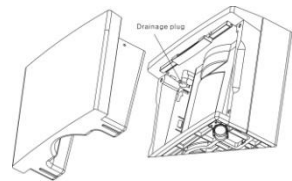

fig. 3

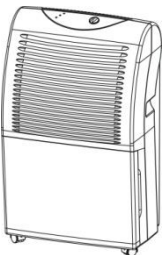

fig.4

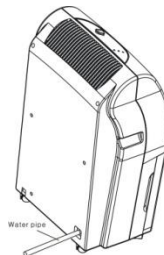

fig.5

CLEANING

Switch the dehumidifier off and remove the plug from the socket before cleaning.

The exterior

Clean the exterior with a soft, dry cloth. If the device is extremely dirty, use a mild cleaning agent.

Wipe the dehumidifier with a slightly damp cloth. Never spray the device with water.

The air filter

When used regularly, the filter may become clogged with dust and particles. Therefore the filter should be checked every two weeks. If the dehumidifier is found to need more regular cleaning then we recommend doing so because a dirty filter can cause the dehumidifier to fail.

1. Remove the water tank as per previous page.
2. The filter is behind the air inlet and can be pulled down with the tank removed.
3. Clean the filter, if you use water to clean the filter then allow it to dry before replacing into the dehumidifier.

Never use the dehumidifier either without a filter or with a dirty filter as both actions could damage the dehumidifier or make the warranty void.

STORAGE

If the dehumidifier is not be used for a long period of time, then take the following steps:

1. Remove the plug from the socket and empty the container. Allow the container and the dehumidifier to dry completely, this can take a couple of days.
2. Clean the air filter.
3. Store the device in a dust-free location away from direct sunlight, preferably covered with a sheet of plastic.

TROUBLESHOOTING

Check the following before contacting technical support:

Problem	Cause	Solution
The unit does not work.	The power is not connected.	Insert the plug into the wall outlet.
The device does not dehumidify.	The water container is full.	Remove the water from the container.
	The water container has not been replaced correctly.	Place the water container in the correct position.
	The air filter is clogged.	Clean the air filter.
	The temperature or relative humidity in the room where the device is operating is too low.	It is normal that the device does not dehumidify in these conditions.
The dehumidifier works, but reduces the relative humidity insufficiently/there is little water in the water tank.	The space to be dried is too large	We recommend using a dehumidifier with a greater capacity or a second dehumidifier.
	There are too many sources of moisture. Bathing, drying clothes and cooking all puts moisture into the air. Calor gas heating can add too much moisture into the air for a dehumidifier.	We recommend using a dehumidifier with a greater capacity. Consider using a different heat source to a calor gas heater.
	There is too much ventilation.	Reduce ventilation (e.g. close windows and shut doors.)
	The air filter is blocked and the reduce air flow is effecting performance.	Clean the air filter.
The windows were clear but condensation has returned.	The outside air temperature has dropped and the windows are colder.	Use the dehumidifier on Maximum and run it 24 hours a day.
I cannot remove the condensation from my windows, even in Maximum mode.	The surface temperature of the windows is too low for a dehumidifier to prevent condensation. Common with single glazed windows.	Keep running the dehumidifier on Maximum 24 hours a day and when the air temperature outside increases the windows should clear of condensation.
Dehumidifier is blowing out warm air.	The dried air is past over heating coils before it is blown into the room as part of the dehumidification process.	This is normal, a dehumidifier is not an air cooler.
The dehumidifier is noisy.	The air filter is blocked or the unit is on an uneven surface.	Clean the filter and or put the dehumidifier on a flat surface. A dehumidifier will also be noisier on wooden floors than on carpet.

CONDITIONS OF WARRANTY

There is a one year warranty on your dehumidifier from the date of purchase. All material or manufacturing defects will be repaired free of charge.

The following applies:

- Any repairs or replacement of components during the warranty period will not result in an extension of the warranty period.
- The warranty will expire if any alterations have been made, not genuine components have been fitted or if the dehumidifier has been repaired by a third party.
- Components subject to normal wear and tear, such as the air filter, are not covered by the warranty.
- The warranty is only valid on presentation of the original, unaltered, and date-stamped purchase receipt.
- The warranty does not cover damage caused by actions that deviate from those as described in the user's manual or by neglect.
- All claims for compensation, including consequential damage, will not be entertained.
- If the air filter is not kept clean then the dehumidifier might fail and Meaco reserve the right not to fix any fault found free of charge.

To prevent unnecessary expenses, we recommend that you always carefully read the user's manual first. If this does not provide a solution, take the dehumidifier to your distributor for repair.

This appliance is not intended for use by person (including children) with reduced physical, sensory or mental capabilities, or lack of experience and knowledge, unless they have been given supervision or instruction concerning use of the appliance by a person responsible for their safety.

Children should be supervised to ensure that they do not play with the appliance.

TECHNICAL SPECIFICATIONS

Model	Meaco 30L	Meaco 40L
Power consumption	500 watts	580 watts
Power supply	220-240V / 50Hz	220-240V / 50Hz
Current (nominal)	2.3A	2.7A
Dehumidifying capacity	30 litres / day (at 30°C, 80%RH)	40 litres / day (at 30°C, 80%RH)
Capacity water container	4 litres	4 litres
Air flow (nominal)	180 m ³ / h	180 m ³ / h
For homes up to	5 bedrooms	5 bedrooms
Operating range	5 – 35°C	5 – 35°C
Automatic defrost	Yes	Yes
Compressor type	Rotary	Rotary
Refrigerant type / charge	R407C/280g	R407C/320g
Dimensions (w x d x h)	410 x 275 x 702mm	410 x 275 x 702mm
Net weight	20.5Kg	20.5kg
Gross weight	23.5Kg	23.5kg
Sound pressure level	49dBA	49dBA



This marking indicates that this product should not be disposed with other household wastes throughout the EU. To prevent possible harm to the environment or human health from uncontrolled waste disposal, recycle it responsibly to promote the sustainable reuse of material resources. To return your used device, please use the return and collection systems or contact the retailer where the product was purchased. They can take this product for environmental safe recycling. Meaco (U.K.) Limited are members of the WEEE recycling scheme and as such this dehumidifier can be taken to your local council recycling centre.



CUSTOMER SERVICE

This dehumidifier has been imported into the U.K. by;

Meaco (U.K.) Limited
Meaco House
Parklands
Railton Road
Guildford
GU2 9JX

Telephone: Freecall 0500 418458
Email: sales@meaco.com
Website: www.meaco.com
Fax: 01483 232700

Meaco are specialists in dehumidifiers and would welcome your comments and questions on this dehumidifier. If you do develop a fault within the first year then please do call us and if we cannot fix the problem over the phone we will be happy to collect the dehumidifier from you at our expense and repair or replace as appropriate.

Please save the box just in case this happens.

Please record, for future reference, your date of purchase and where you bought the dehumidifier from here.

Date of purchase.....

Purchased from www.meaco.com (if not then please record the supplier's name below).